

1 TYPICAL CONDENSING UNIT DETAIL
SCALE: NTS

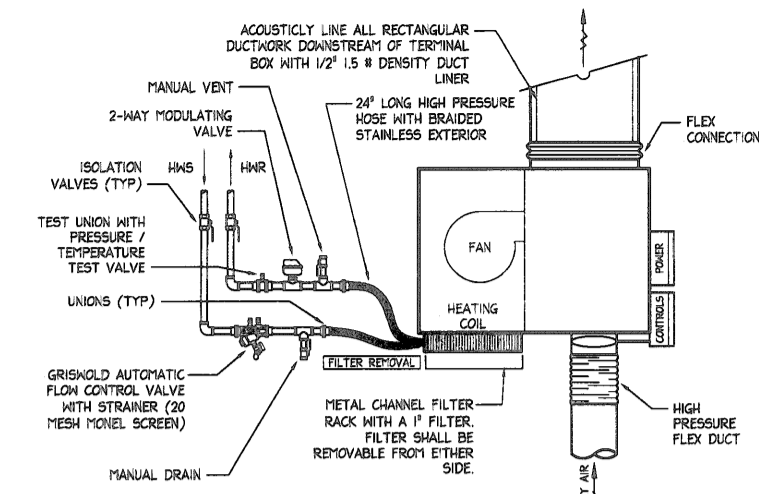

2 TYPICAL FAN POWERED TERMINAL BOX DETAIL
SCALE: NTS

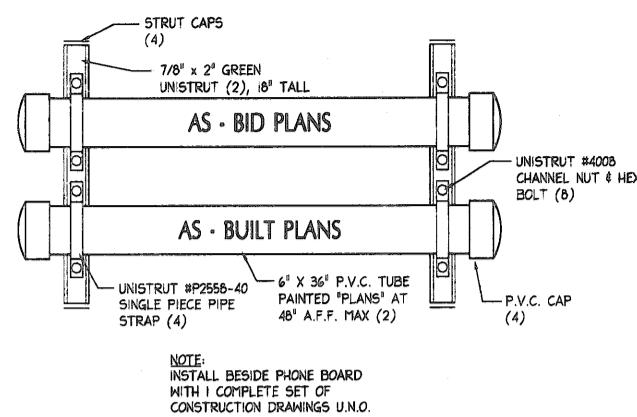

3 PLAN TUBE DETAIL
SCALE: NTS

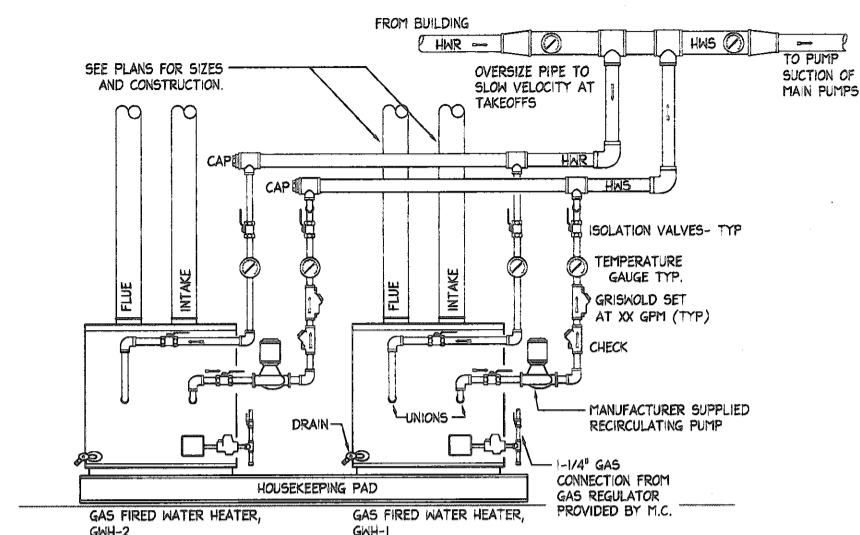

4 WATER BOILER DETAIL
SCALE: NTS

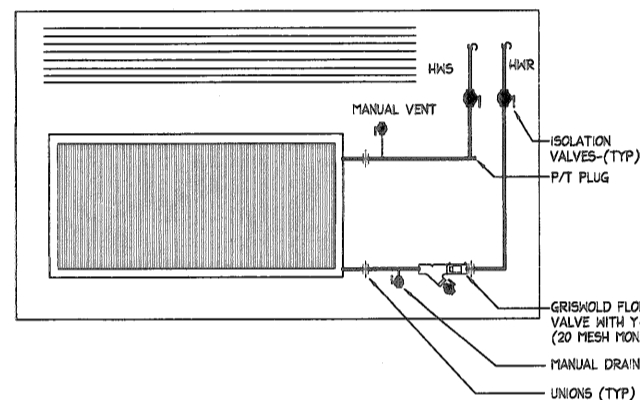

7 TYPICAL CABINET HEATER DETAIL
SCALE: NTS

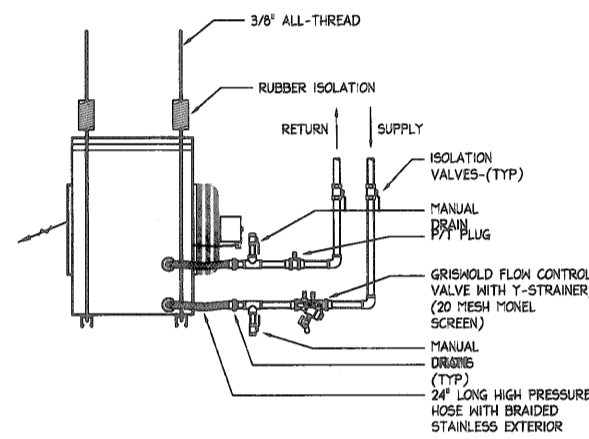

6 TYPICAL UNIT HEATER DETAIL
SCALE: NTS

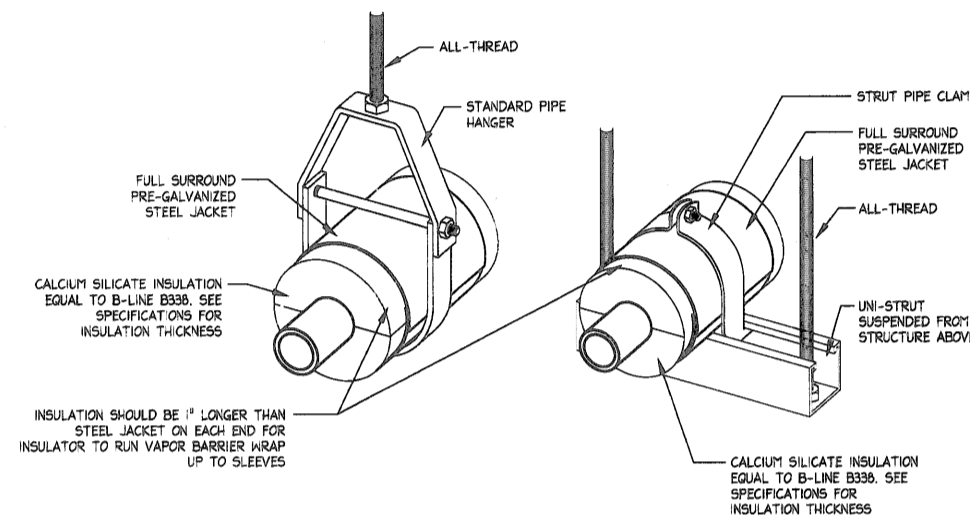

11 TYPICAL PIPE SUPPORT DETAIL
SCALE: NTS

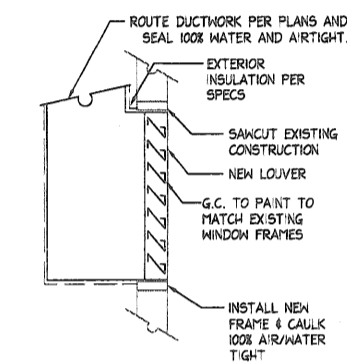

5 TYPICAL "PATCH" RELIEF DETAIL
SCALE: NTS

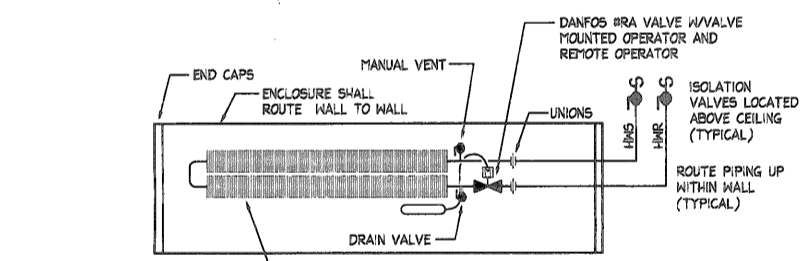

8 TYPICAL WALL MOUNTED FIN-TUBE DETAIL
SCALE: NTS

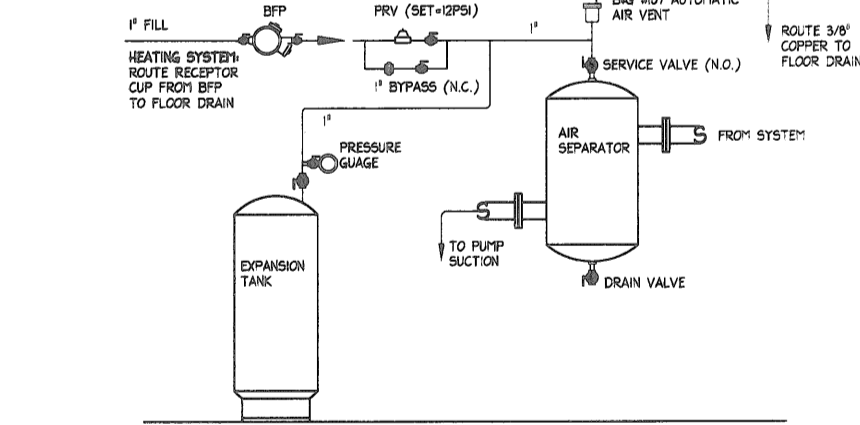

10 TYPICAL AIR SEPARATOR DETAIL
SCALE: NTS

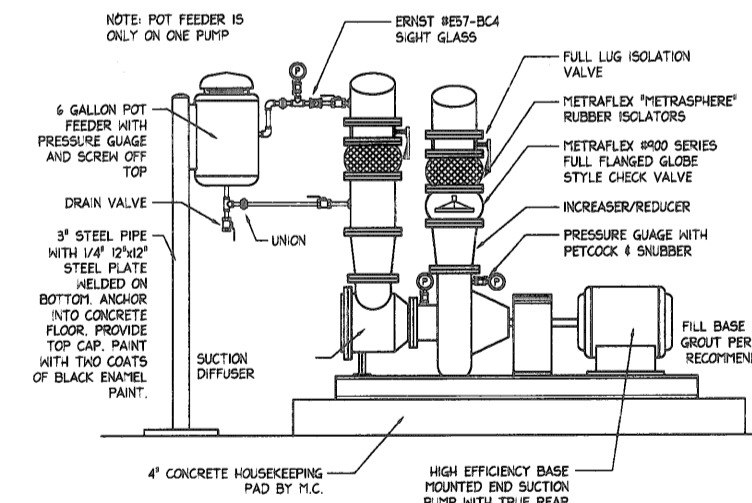

12 TYPICAL BASE MOUNTED PUMP DETAIL
SCALE: NTS

MECHANICAL SYMBOLS (NOT ALL SYMBOLS APPLY TO THESE SHEETS)

EC	ELECTRICAL CONTRACTOR
FP	FIRE PROTECTION CONTRACTOR
TCC	TEMPERATURE CONTROL CONTRACTOR
MC	MECHANICAL CONTRACTOR
SMC	SHEET METAL CONTRACTOR
MD	MANUAL DAMPER
MOD	MOTOR OPERATED DAMPER
FD	FIRE DAMPER
RG	RETURN REGISTER
EG	EXHAUST GRILL
EF	EXHAUST FAN
TB	TERMINAL BOX
RA	RETURN AIR
SA	SUPPLY AIR
OAL	OUTSIDE AIR LOUVER
EAL	EXHAUST AIR LOUVER
BD	BACKDRAFT DAMPER
TH	THERMOSTAT
SM	SHEET METAL TRANSITION
TS	TAMPERS SWITCH
FS	FLOW SWITCH
PG	PRESSURE GAUGE
TR	THERMISTOR
FD	FLOOR DRAIN
S	SINK
WC	WATER CLOSET
L	LAVATORY
U	URINAL
MB	MOP BASIN
CO	CLEANOUT
HB	HOSE BIBB
WTV	WATER MIXING VALVE
VTR	VENT THRU ROOF
LAT	LEAVING AIR TEMPERATURE
LNT	LEAVING WATER TEMPERATURE
EAT	ENTERING AIR TEMPERATURE
ENT	ENTERING WATER TEMPERATURE
MAT	MIXED AIR TEMPERATURE
VFD	VARIABLE FREQUENCY DRIVE
TSP	TOTAL STATIC PRESSURE
ESP	EXTERNAL STATIC PRESSURE
ENT	ENTERING WATER TEMPERATURE
CFM	CUBIC FEET PER MINUTE
F.C.	FORWARD CURVED FAN
FFF	FNS PER FOOT
APD	AIR PRESSURE DROP
GPM	GALLONS PER MINUTE
TCP	TEMPERATURE CONTROL PANEL
MSH	1000 BTU PER HR
HP	HEAT PUMP
FDC	FIRE DEPARTMENT CONNECTION
CHWS	CHILLED WATER SUPPLY
CHWR	CHILLED WATER RETURN
HWS	HOT WATER SUPPLY
HWR	HOT WATER RETURN
HPS	HEAT PUMP SUPPLY
HPR	HEAT PUMP RETURN
S	SUCTON
L	LIQUID
CA	VENT FROM FURNACE
C	COMBUSTION AIR TO FURNACE
G	GAS
CW	COLD WATER (DOMESTIC)
HW	HOT WATER (DOMESTIC)
HW	HOT WATER RETURN (DOMESTIC)
ST	STORM
ST	WASTE (SANITARY)
ST	VENT (SANITARY)
ST	SUPPLY AIR DUCTWORK
ST	STORY ABOVE CEILING
ST	WASTE ABOVE CEILING (SANITARY)

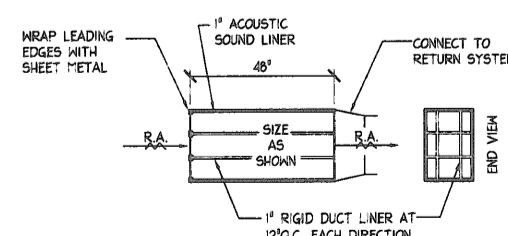

13 SOUND TRAP DETAIL
SCALE: NTS

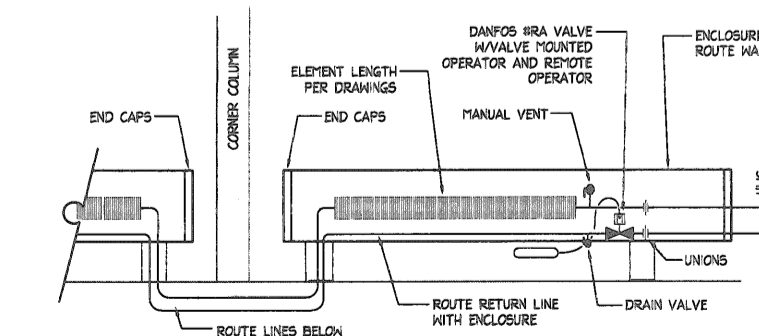

9 TYPICAL PEDestal MOUNTED FIN-TUBE DETAIL
SCALE: NTS



CERTIFICATION
TERRENCE J. WAGNER
REGISTERED PROFESSIONAL ENGINEER
No. 20707
STATE OF INDIANA
Terrence J. Wagner

All drawings, ideas, designs, photos and details as shown on this document are the sole property of Design Collaborative, Inc. and shall not be used for any purpose without their expressed written consent. The owner shall be permitted to view copies for information and reference.

Wells County Public Library
200 West Washington Street
Bluffton, Indiana 46714



REVISION DATE BY

DATE PROJECT
11/2/2005 2005.0039

TITLE
Mechanical Details

SHEET

M4.2